



Track-Dumper



- high power transmission
- high agility by steering brakes
- high climbing ability – possible to drive across steps
- transport / handling of bulk goods and general cargo
- hydraulic tipping

Applications: horticulture, construction, interior demolition, swimming pool construction, wood transport, gardens, areas with difficult ground and spaces where wheelbarrows are physically too difficult.

RD 500 R



Track-Dumper RD 500 R

Technical Data

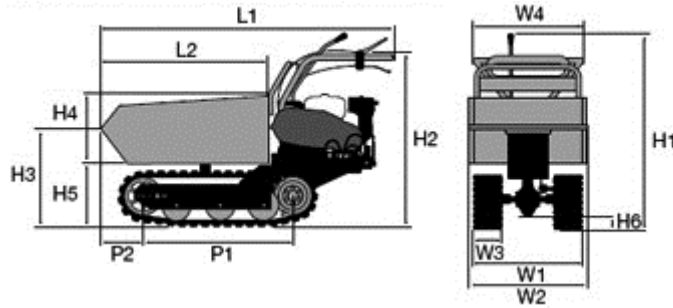

	mm	inches
L1	1650	64.96
L2	1000	39.37
H1	990	38.98
H2	960	37.80
H3	270-515	10.62 - 20.28
H4	460	18.11
H5	340	13.39
H6	80	3.15
W1	710	27.95
W2	710	27.95
W3	180	7.09
W4	590	23.23
P1	880	34.65
P2	300	11.81

Engine	Briggs & Stratton 950 series
Type	1-cylinder-4-stroke
Displacement	205 cm ³
Engine output	5.0 kW / 6.5 HP
Revolution speed	3600 rpm
Starter	Reversing starter
Air filter	Dry cartridge
Fuel filter	Seive

Drive	Toothed gearing, shifting in oil-bath
Brake	Automatic safety brake
Guidance	Steering brake
Characteristic	Hydraulic tipping device

Operation	
Weight	250 kg / 551.2 lbs.
Payload max.	500 kg / 1102.3 lbs.
Tipping device	Hydraulic
Climbing ability	Max. 26° (50%)
Working speed	1.57 km/h / 0.98 mph gear 1 forward 2.93 km/h / 1.82 mph gear 2 forward 3.66 km/h / 2.27 mph gear 3 forward 1.20 km/h / 0.75 mph reverse
Optional load carrying beds	
Bed length adjustable	1025 - 1155 mm / 40.35" – 45.47"
Bed width adjustable	600 - 860 mm / 23.62" – 33.86"
Load height	325 mm / 12.80"

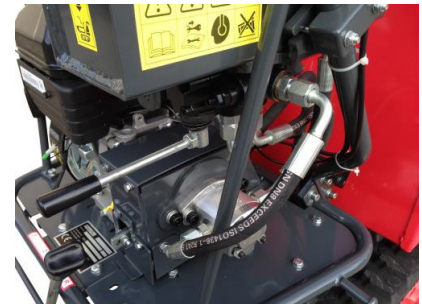

GNH GREAT NORTH HARDSCAPE
SOLUTIONS SIMPLIFIED

orders@gnhardscape.com
www.greatnorthhardscape.com
1.800.720.7627